

Smart Lock



6-in-1 Unlocking Modes

(Face, Fingerprint, Card,

Password, Mechanical Key and Wireless Unlock)

Dummy Password Function

Semiconductor Fingerprint Module

3D Facial Recognition

Cat Eye Camera

EMW8315G-HK



Thank you for choosing a Panasonic product. Please read the instruction manual carefully before use and keep it for future reference.

■ Please complete the warranty registration section and return it to Shun Hing Electric Service Center Ltd., and ensure you retain your warranty record card.

■ The Company reserves the right to interpret any printing errors or misunderstandings in the content of this manual.

■ The images in this manual are for illustrative purposes only; please refer to the actual product.

■ Should there be any technical improvements, they will be included in the new version of the manual without prior notice; the appearance and color of the product are subject to change, and the actual product will prevail.

Safety Precautions

Safety Precautions (Please read and comply with the safety guidelines thoroughly)

- ⊗ Before using the smart lock, ensure you have read and understood all instructions. Failure to follow these instructions may result in damage not covered under warranty.
- ⊗ Adhere to the warnings and cautions outlined below to prevent injury or property damage to users or others.

Warning

- ⊗ Do not install, dismantle, repair, modify, or alter the product yourself, nor use non-original parts from manufacturers for repairs, as it may pose hazards and void the warranty.
- ⊗ Avoid using sharp objects (such as pens, awls, or needles) to press buttons or insert into the keyhole.
- ⊗ Do not subject the product to strong impacts, drops, pulls, or strikes with hard or heavy objects.
- ⊗ Do not hang items on the handle to ensure normal operation of the lock.
- ⊗ The product should not be installed in outdoor environments exposed to the weather change.
- ⊗ Avoid using the product in high-temperature environments.
- ⊗ Prolonged exposure to sunlight can cause the touchpad to crack; install the product away from direct sunlight.
- ⊗ Do not use or place batteries near heat sources (like fire, heaters, or intense sunlight) as it may cause overheating or fire and result in reducing battery life.
- ⊗ Ensure no liquids penetrate the product.
- ⊗ Do not install the product in environments prone to leaks or splashes, and do not operate it underwater.
- ⊗ Avoid spraying insecticides or flammable sprays around the product, as it may cause damage.
- ⊗ Keep batteries away from any liquids and store them in a cool, dry place when not in use.
 - Do not reverse the polarity of batteries or short-circuit them with metal objects, as it may cause explosions.
 - Do not transport or store batteries with metal objects like hairpins or necklaces.
 - Refrain from knocking, throwing, or stepping on batteries.
 - Avoid using the product in areas with strong static electricity or magnetic fields as they can damage the battery's safety protection features and trigger risks.
 - Magnetic functions may be disrupted by various factors; this is not a fault of the device. Consider resetting the magnetic function or using the delay lock function.

Safety Precautions

Cautions

- Manage your passwords carefully and change them regularly for security; always ensure the door is fully locked when leaving home. The Company is not responsible for incidents due to user negligence.
- Store mechanical keys securely for emergency use.
- Be careful not to bump into handles to avoid injuries.
- Product in wireless communications may be subject to interference which may affect operation.
- This product is suitable for use by children and individuals with physical, sensory, or mental disabilities, or those lacking experience and knowledge, under close supervision and guidance of a responsible adult so that they can safely use the product and understand potential dangers.
- To prevent dirt accumulation on the keypad and fingerprint sensor, regularly wipe the lock body with a soft cloth. Do not directly wash with water or use benzene, alcohol, or corrosive chemical cleaners.
- Frequent forceful door closing may damage the lock body. Avoid slamming the door when the latch is extended.
- Adjust the lock promptly if the door or frame deformations prevent proper locking of the latch.
- Lithium batteries should not be fast-charged. If stored or unused for prolonged periods, charge them every six months to prevent damage from self-discharge.
- Replace all batteries promptly when power is low and ensure correct installation of battery terminals.
- In case of battery leakage and electrolyte contact with eyes, do not rub; rinse with water and seek medical attention immediately to prevent eye injury.
- If the battery emits an odor, heats up, changes color, deforms, or shows any abnormality during use, storage, or charging, remove it immediately from the device or charger and discontinue use.
- Clean dirty battery terminals with a dry cloth before use to prevent poor contact and malfunction.
- Dispose of spent batteries properly by insulating the terminals to prevent fires or explosions. Do not dispose of with regular household waste.
- If the product malfunctions, or if the power cord is exposed or damaged, do not use the product. To avoid hazards, have it repaired by Shun Hing Appliance Service Center Ltd.
- Keep the product warranty card and purchase receipt safely for future warranty claims.

Table of Contents

I.	Product Overview-----	01
	1. Illustrated Guide to the Product-----	01
	2. General Operating Principles-----	01
II.	Functions and Operations-----	02
	1.Factory Settings-----	02
	2.Introduction on Operation-----	02
	3.Initial State: First Access to Administrator Options-----	02
	4.Accessing Administrator Options-----	02
	5.Adding Users-----	03
	6.Deleting Users-----	05
	7.System Settings-----	06
	8.Battery Replacement-----	08
	9.Emergency Power Supply-----	08
	10.Removing and Installing Lithium Battery-----	09
	11.Additional Information-----	09
III.	Downloading Apps and Network Connection-----	10
	1. App Download-----	10
	2. App Operation-----	10
IV.	Technical Parameters-----	16
V.	Frequently Asked Questions-----	17
VI.	Product List-----	18
VII.	After-sales Service-----	19

I. Product Overview

1. EMW8315G-HK Illustrated Guide to the Product

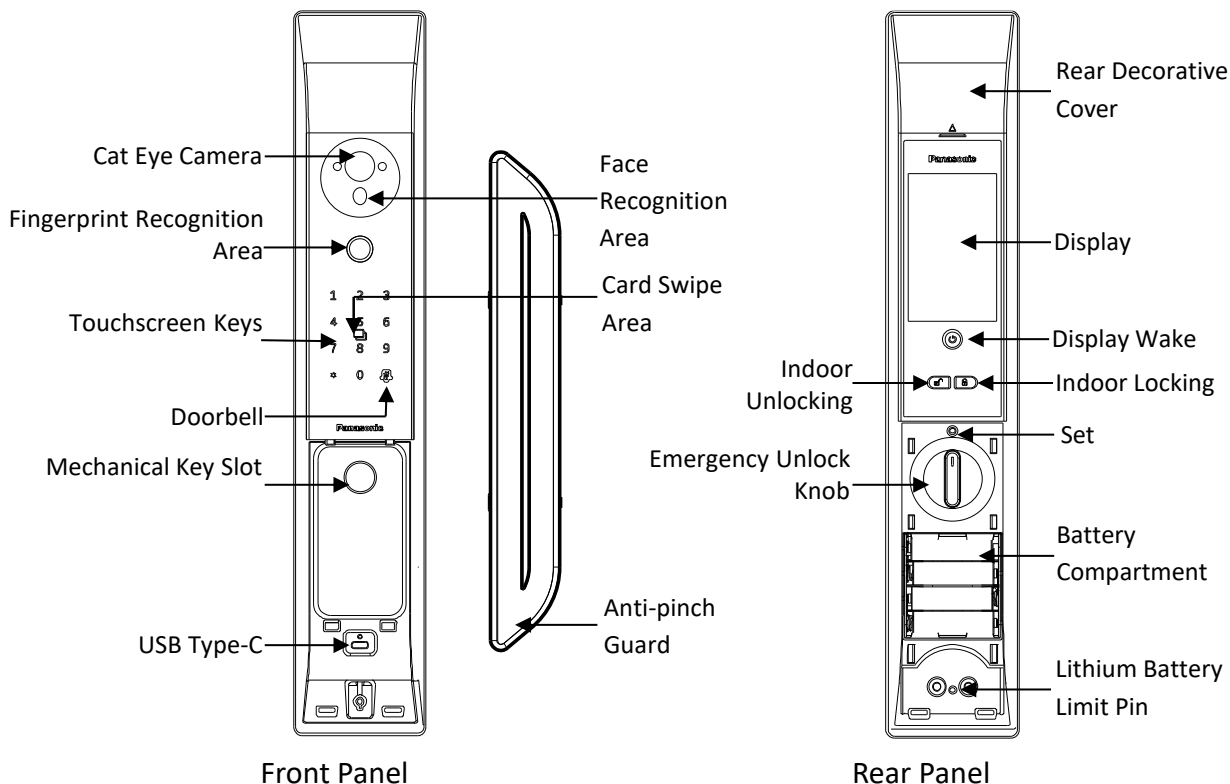

Note: For unlocking, gently place your finger horizontally on the touchscreen and slide it up or down within the keypad area to activate the touchscreen.

2. General Operating Principles

“*” - Short press to clear/return

Long press to enable the one-touch arm mode (After closing the door, press and hold the “*” key until it lights up, and a beep is heard to confirm successful setup)

“#” - Press to confirm

“05#” - Press to enable or disable human detection (administrator verification required)

“06#” - Press to report mainboard/powerboard version

“Beep ” - Successful

“Double Beep ” - Wrong

“SET” - Hold for 5 seconds to initiate a factory reset with a voice prompt confirming the reset

“Anti-pinch Guard ” - Removable and adjustable according to the door direction

II. Functions and Operations

1.Factory Settings

💡 Upon initial setup, the door lock is configured with a default password: "123456#". When this password is entered to unlock the door, an audio prompt will confirm the Factory Settings.

2.Introduction on Operation

"#" - A function key to confirm; "*" - A function key to clear or return upon short press

System emits a "double beep" to indicate error. (E.g., the same password is added.)

3.Initial State: First Access to Administrator Options

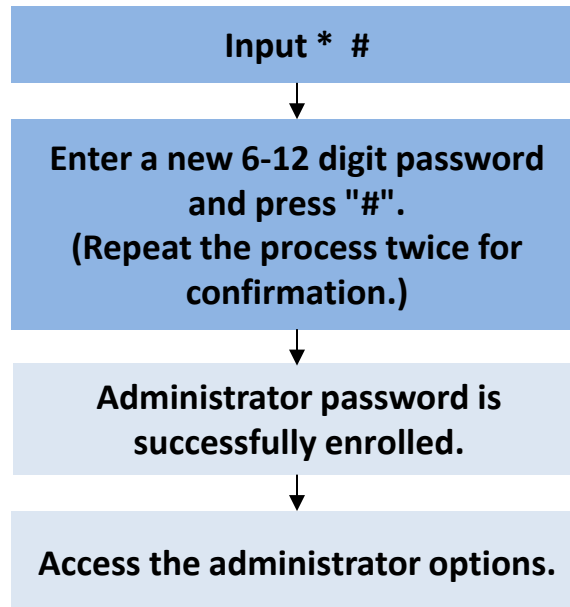

4.Accessing Administrator Options

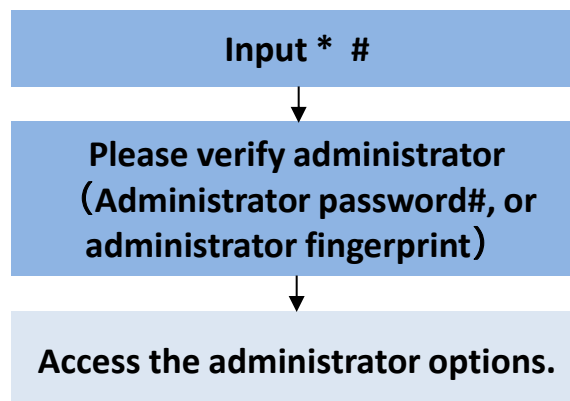

II. Functions and Operations

5. Adding Users

5.1 Administrator

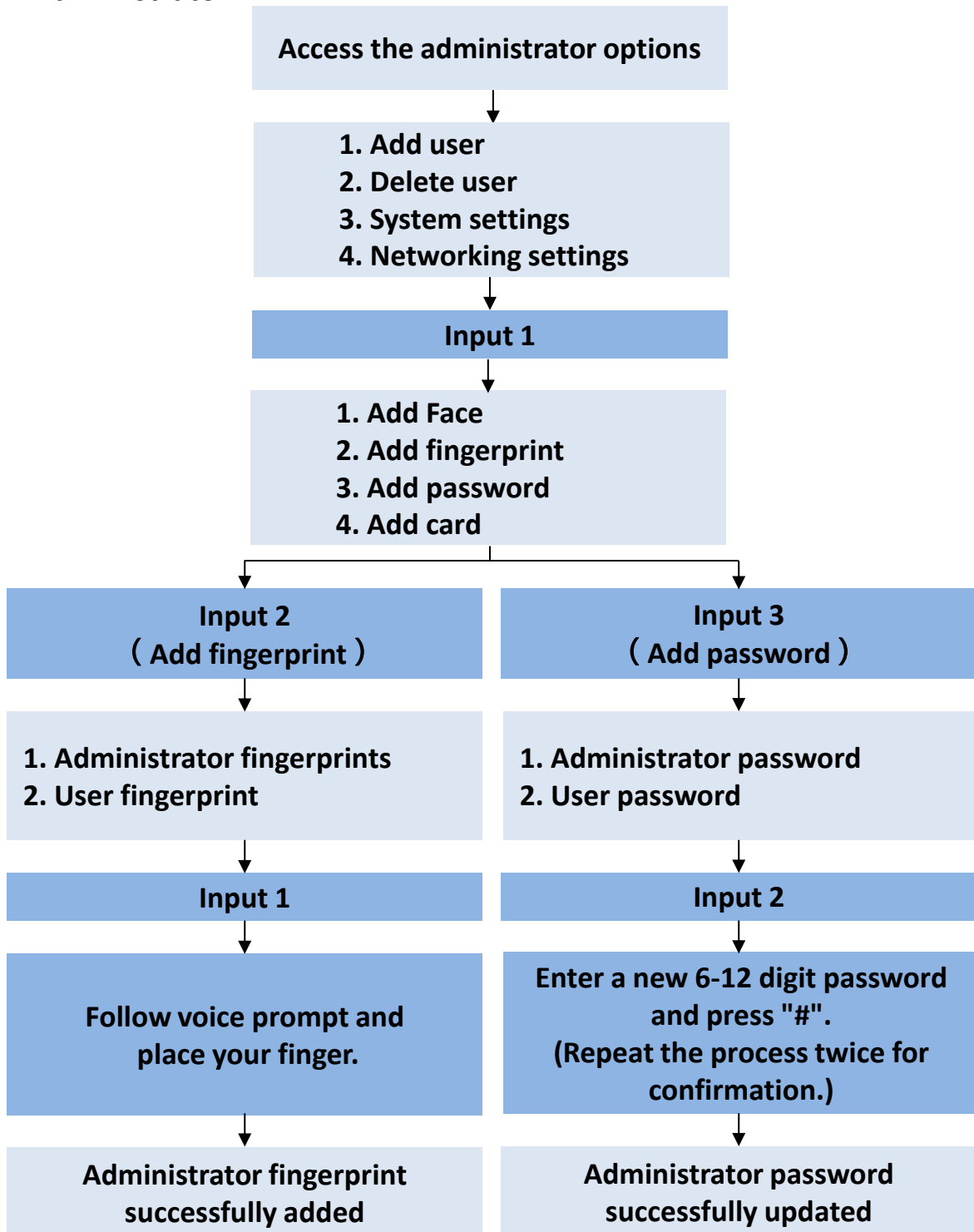

Note: Only one administrator is allowed. Upon entering a new administrator password, the previous one is automatically deleted.

II. Functions and Operations

5.2 Normal User

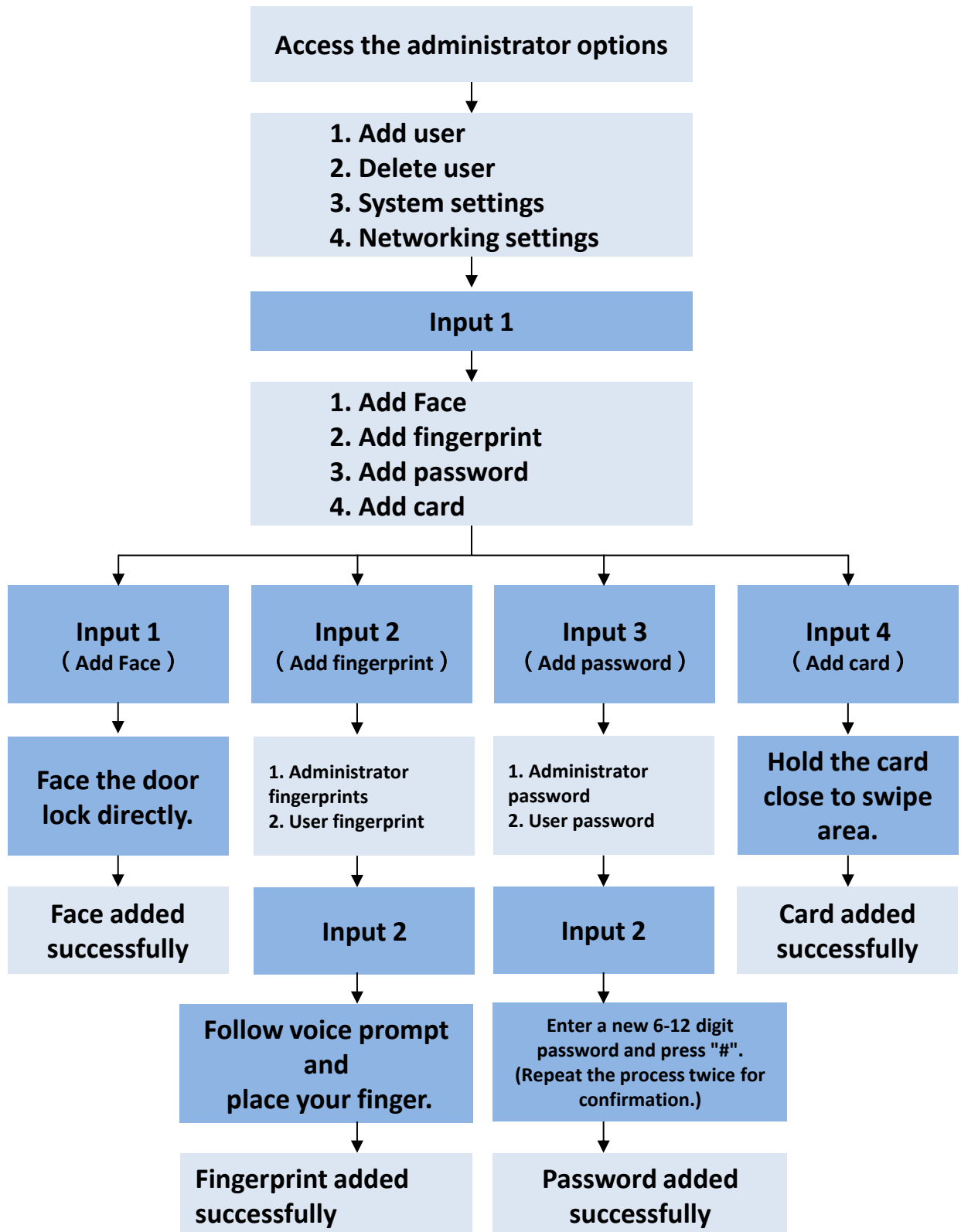

II. Functions and Operations

6. Deleting Users

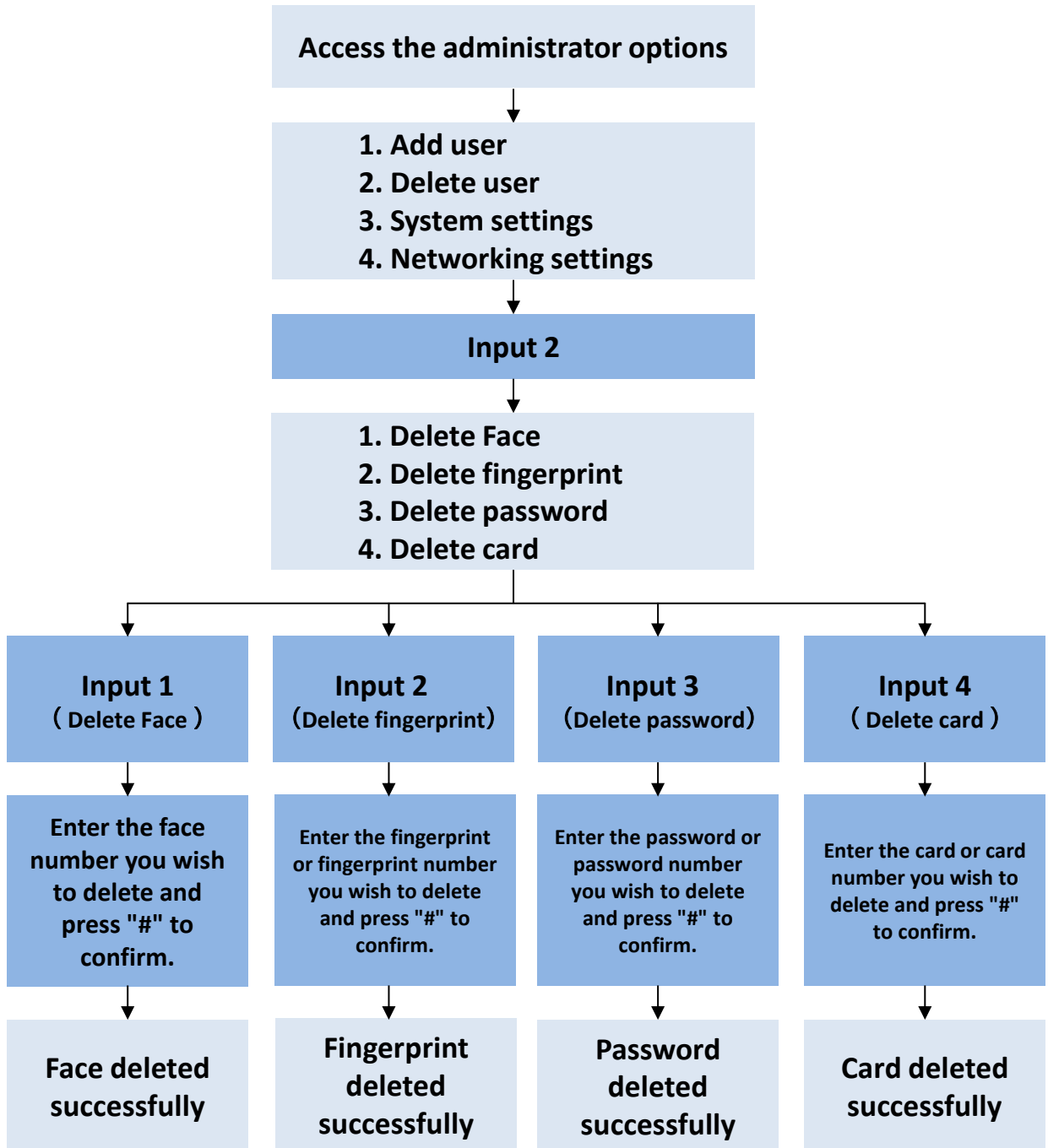

Note: The current administrator accessing the administrator options cannot be deleted.

II. Functions and Operations

7 System Settings

7.1 System Settings (Unlock Mode, Volume Control)

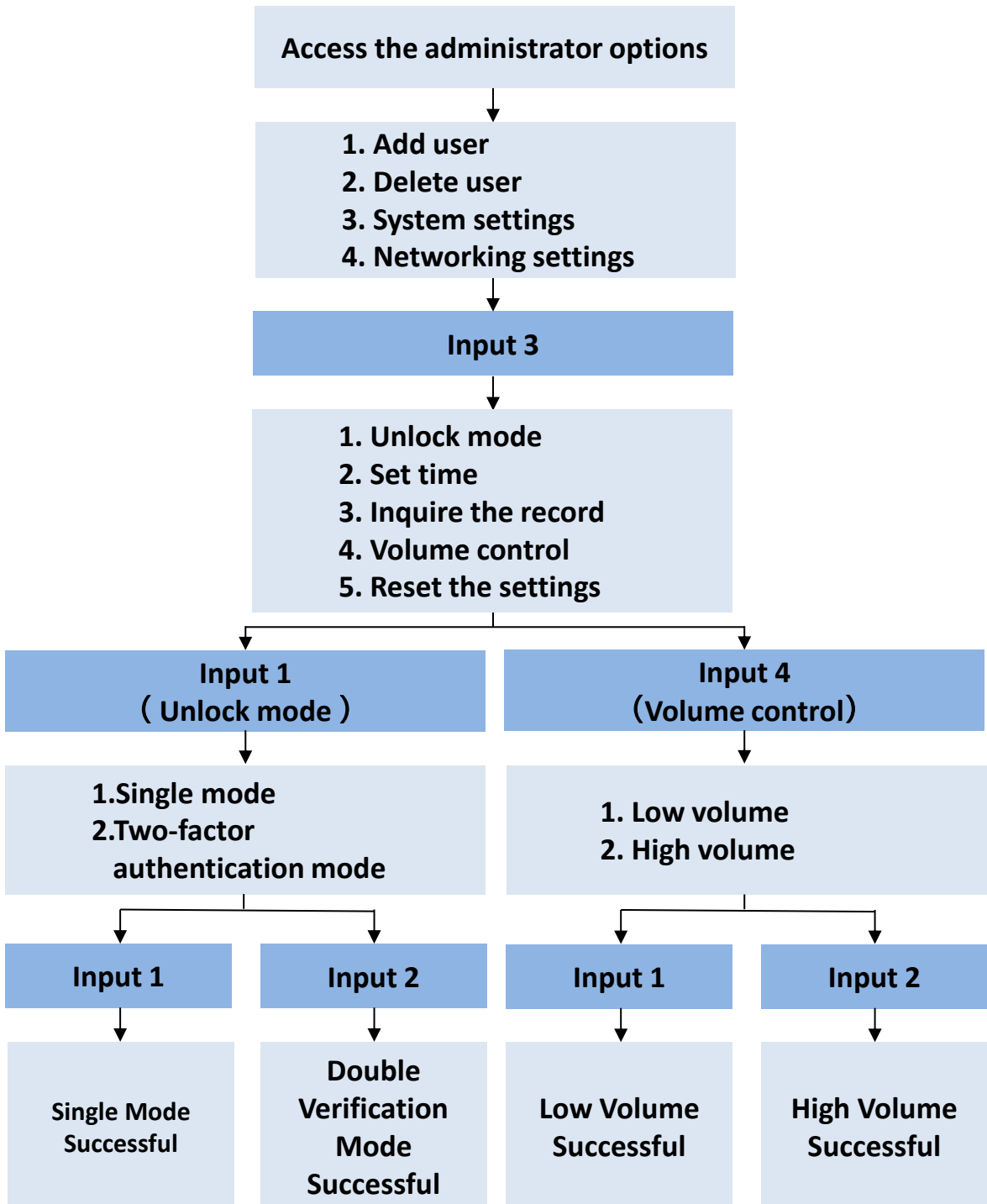

Note: In double verification mode, any of the administrator passwords is able to unlock the device.

II. Functions and Operations

7.2 System Settings (Set Time, Inquire the Record, Reset the Settings)

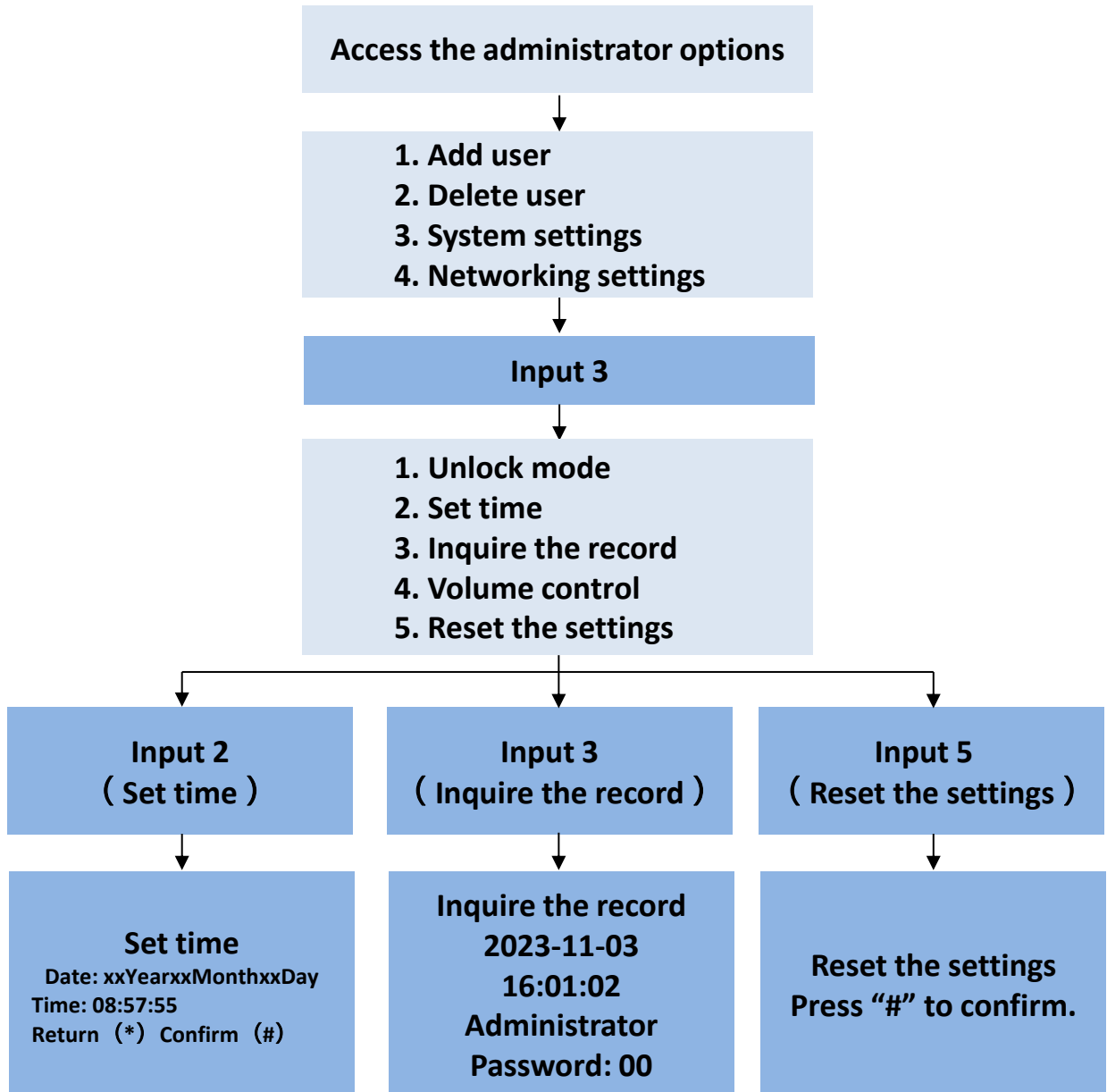

Note:

Set Time: Enter the desired time using the numeric keys. For example, to set the time to "15:24:30 on January 27, 2024," press "240127152430" followed by the "#" key to confirm. In network mode, the time will automatically synchronize.

Inquire the record: The storage limit is 500 entries, numbered from 001 to 500. When full, new entries will overwrite starting from 001. Press "2" to move to the previous record and "8" to move to the next record.

II. Functions and Operations

8. Battery Replacement

When the dry battery is low on power, the voice prompt will be given as "Low battery, please renew." Promptly replace the battery to ensure continued functionality. **Note:** Always use the original alkaline batteries purchased from the official channel.

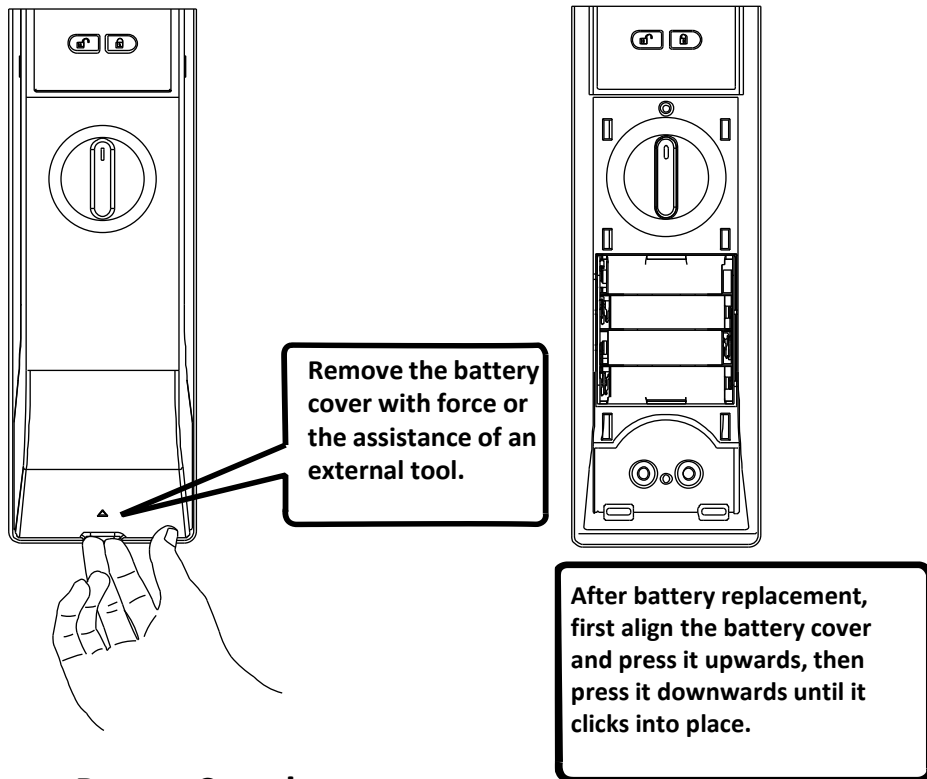

9. Emergency Power Supply

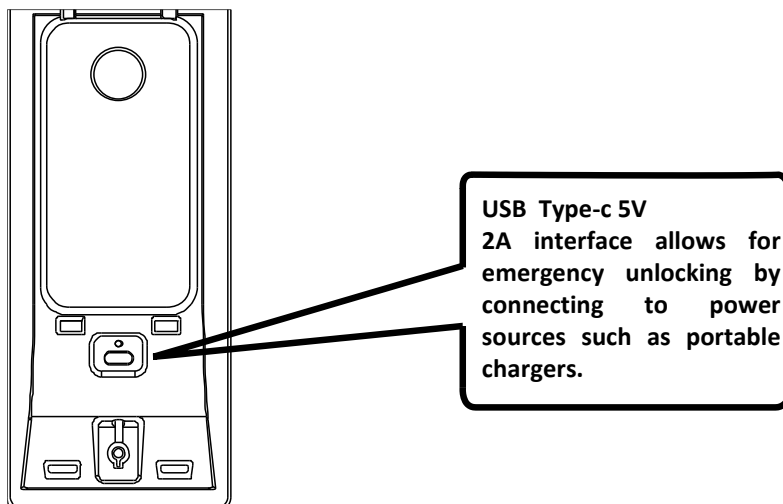

II. Functions and Operations

10. Removing and Installing Lithium Battery

● To install the lithium battery, open the battery cover, insert the battery until the safety button pops up, and the installation is complete.

● To remove the lithium battery, open the battery cover, press the safety button, and withdraw the battery. Then the removal is complete.

Note: The lithium battery does not support fast charging. For replacement, always purchase the official original lithium battery to avoid damaging the electric lock.

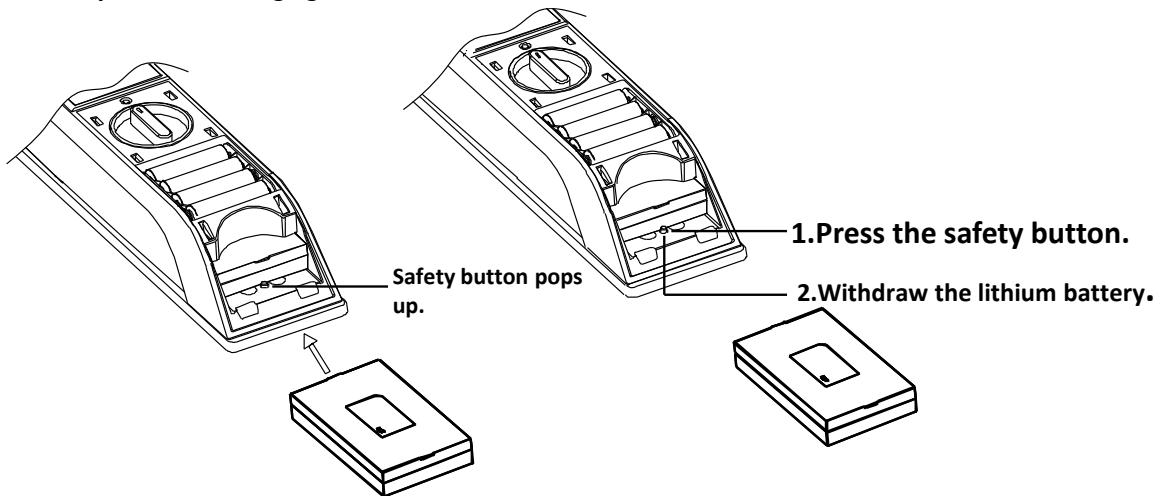

11. Additional Information

● After five consecutive incorrect access attempts, the lock will emit two beeps and the keypad will be locked for 10 seconds.

● Tampering with the door will trigger an alarm, which can be deactivated by either the administrator or user information.

● For first-time users, please initialize the product and re-register the administrator to prevent any unnecessary losses.

● The system will automatically log out after prolonged inactivity.

Dummy Password Function—Enter “XXXPasswordXXX”. Enter irrelevant digits before and after the actual password and press the “#” key to unlock when the correct password is included but the total length falls short of 20 digits. An error will be reported with voice prompt “Beep, Beep” when the total length with the correct password included exceeds 20 digits. (The authentic password must be within 20 digits.)

Note: The Dummy Password Function is highly recommended to prevent the correct password from being exposed.

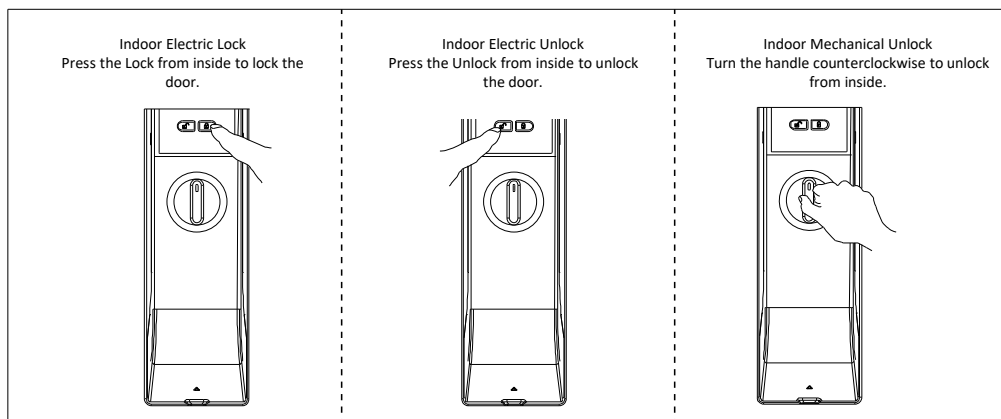

III. Downloading Apps and Network Connection

1.APP Downloading and Installing

Download the Shun Hing Group APP: Scan the QR code below, or visit Google Play/Apple's "App Store" to download and install.



2.APP Operation

1)Account Registration

- ① Upon first opening the App, a user notice will appear. Click "Agree" to proceed;
- ② Click on "Register";
- ③ Select your region, enter your email, check "I agree to the User Agreement and Privacy Policy", then click "Get Verification Code". Enter the verification code, and you will be automatically directed to the next step.

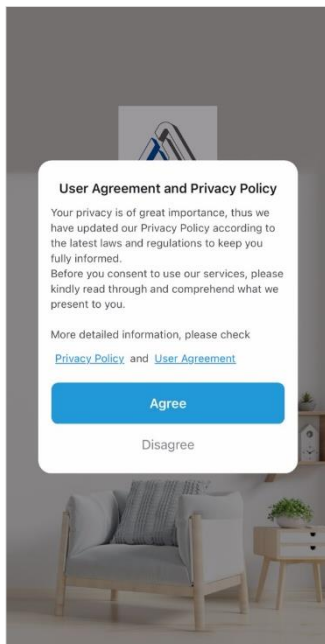

①

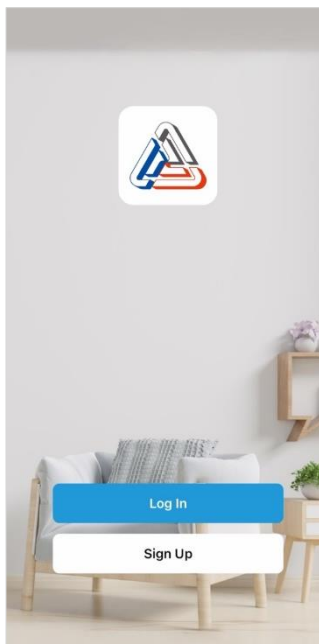

②

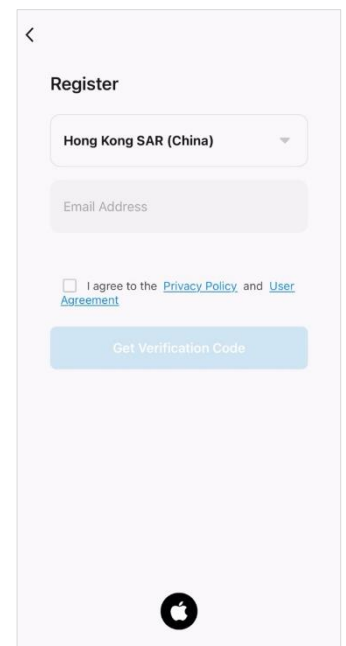

③

III. Downloading Apps and Network Connection

④ Enter the Set Password interface, configure your password (which should be a combination of numbers and letters, 6 to 20 characters long), and click "Finish" to complete the registration and proceed to the next step.

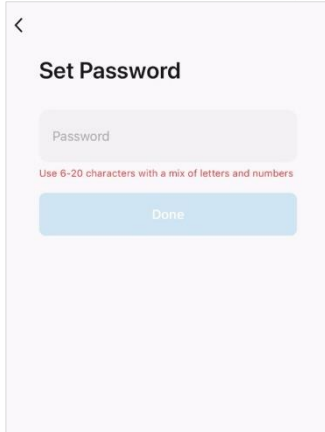

④

2) Adding Device

When adding a device, ensure your phone is connected to WiFi, and both the door lock and your phone are on the same WiFi network. Enter the pairing mode on the lock to begin the setup process.

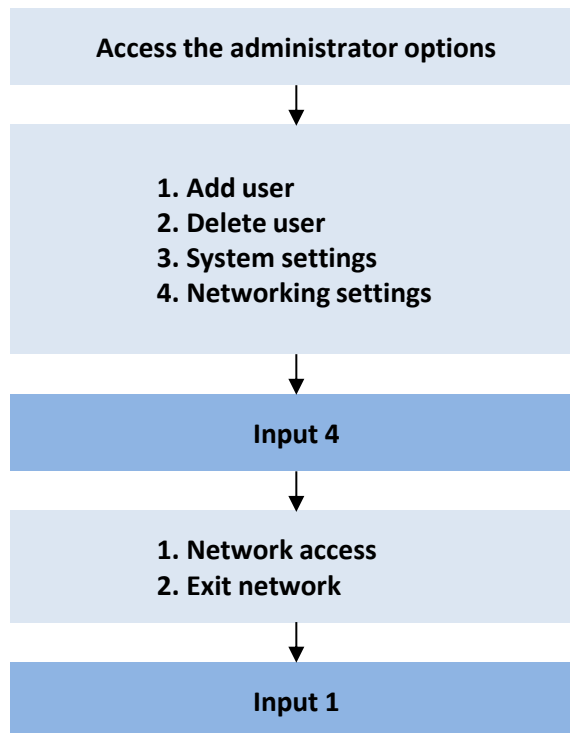

III. Downloading Apps and Network Connection

- ① Click on "Add Device" or the "+" icon at the top right to access the "Add Device" page;
- ② During the auto-discovery process, certain permissions will be required. Once all permissions are granted, the system will automatically search for nearby devices. Upon discovering a device, click "Add.";
- ③ select your home's 2.4GHz Wi-Fi network, enter the Wi-Fi password, and click "Next";

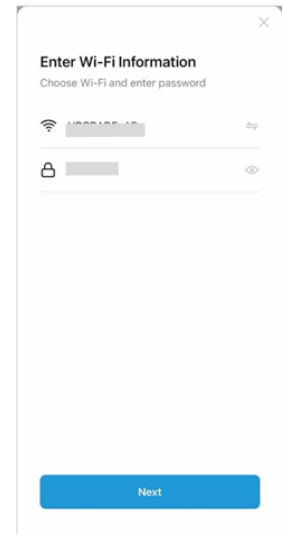

- ④ Proceed to the connecting interface and wait for a few seconds. The lock will indicate that the addition was successful;
- ⑤ After clicking "Finish," you will be directed to the device panel interface.

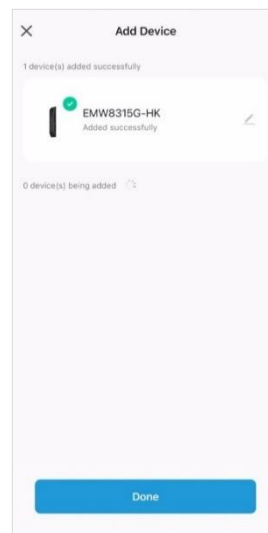
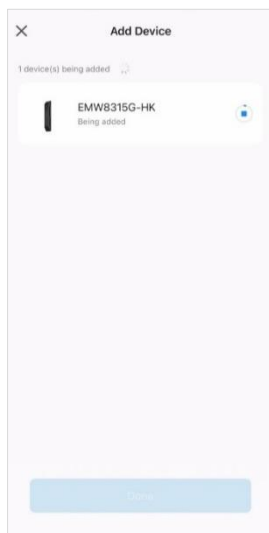

④

⑤

III. Downloading Apps and Network Connection

Network Configuration instructions:

The WiFi configuration mode has one-minute limit; if exceeded, it will automatically exit. If WiFi configuration fails, please check the following:

①Ensure the WiFi password is correct and that the network name does not contain special characters.

②Make sure the device is connected to a 2.4G frequency WiFi network.

③Ensure the device, phone and router are within 1 meter of each other during configuration.

After confirming the above, remove and reinsert the lithium battery, then retry the network setup.

3)Remote Unlock

Visitors should touch the doorbell on the lock. Once the homeowner answers the voice call, the visitor should press and hold the unlock button to open the door.

4)Temporary Password

On the main page of the App, select your device, then tap "Temporary Password." Here, you can customize the password based on your needs, choosing from options like time-limited, one-time use, dynamic, clear, or custom types.

Note: Once set, temporary passwords cannot be viewed again, so please save them promptly.

Enter the temporary password and press “#” to verify.

Password incorrect or expired

Voice Prompt: Beep, Beep

Unlock successful

Voice Prompt: door opening sound effect

5)Device Sharing

Device can be shared with friends and family. On the App's main page, select the device to be shared, then click "Member Management". Click the "+" icon in the top right to enter the member addition interface. Follow the prompts to fill in the information and share. The shared user must agree before using the shared device's functions.

Note: Only the primary user of the device can use the sharing function. The shared user must be registered and logged into the Shun Hing Group App; otherwise, the sharing function will not be available.

III. Downloading Apps and Network Connection

6) User Unlock Records

On the main page of the App, select your device and tap "Album/Logs". In the album, choose a date to view all event records. In the "Logs", check alarm messages and door opening records.

Note: If the door lock is not connected to the network when the door is opened, the opening record will not be uploaded to the cloud, potentially resulting in the loss of the record.

7) Passive Alarm Function

① On the lock, input "05#" to enable human detection (requiring administrator verification).

② On the main page of the App, select your device, tap "Settings", then "Passive Detection," and finally "General Alarm".

Note: After enabling the passive alarm function, if someone stays near the door, it will automatically take picture and upload to the App. This function will slightly increase battery consumption.

8) Video Surveillance

On the main page of the App, select your device and tap "Video Surveillance". Here, you can view the scene outside the door. In this interface, you can use the "Click and Speak" function to talk to someone outside.

Note: This function will be disabled when the lock is in sleep mode or low battery state. This function will significantly increase battery consumption.

9) One-Click Arming

Operate on the lock, after closing the door, press and hold "*" when it lights up. You will hear a "beep", indicating the setting is successful. When unlocking from the inside, the lock will emit an alarm sound. If the lock is bound to the App, an alarm message will be pushed to the App.

Note: Arming mode can be deactivated by unlocking from the outside using any verification method. If the door lock is not connected to the network when the door is opened, the alarm information will not be uploaded to the cloud.

10) Unbind Device

Open the Shun Hing Group App → Press and hold the device to be unbound → Remove Device

III. Downloading Apps and Network Connection

11) Hijack User Alarm Setting

- ① Enter Member Management, select the member to add hijack information, and click "Add Password";
- ② Enter the desired unlocking information, with the "Hijack Password" shown in the image below as the example;
- ③ Turn on the switch next to "Hijack Password" (indicated by a green color);
- ④ Check the box to select the notification method, then click "Save". Each time the Hijack Password 1 is used to unlock, the device owner will receive a notification on his or her phone.

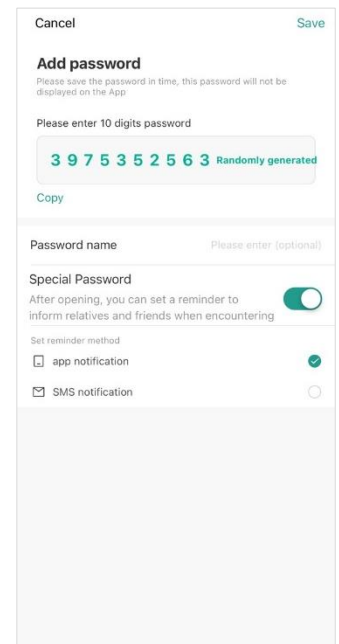
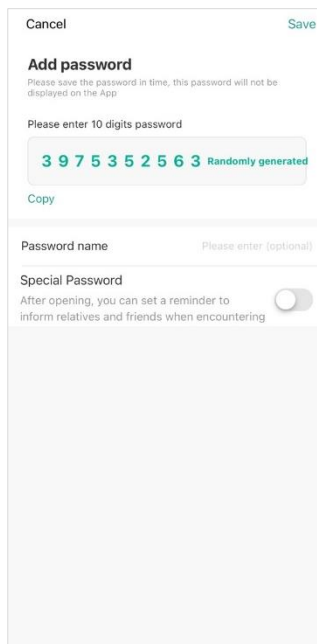
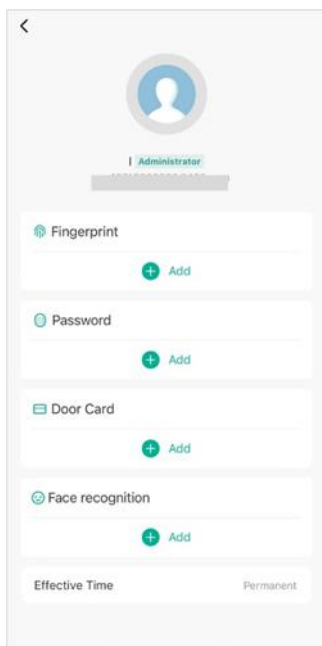

ATTENTION: when using a hijack alarm user to unlock the door, the lock will open normally without sounding an alarm. However, an alarm message will be pushed to the App. But if the door lock is not connected to the network when the door is unlocked, the alarm information will not be uploaded to the cloud.

IV. Technical Parameters

Type	Description
Front Panel Dimensions (HxWxD)	438mm × 80mm × 61mm
Rear Panel Dimensions (HxWxD)	438mm × 80mm × 61mm
External Materials	Aluminum Alloy
Latch Materials	304 Stainless Steel
Touch Keys	12
Dry Battery	4 *AA batteries
Lithium Battery	5,000mAh Lithium Battery
Emergency Power	Emergency Power Supply USB Type-c
Card	Mifare one Card
Unlock Modes	Face, Fingerprint, Card, Password, Mechanical Key, App
Unlock Records	5,000
Administrator Users	11
Normal Users	289
Total Number of Users	300
Maximum Number of Fingerprints	50
Working Temperature	-25°C~50°C
Relative Humidity	≤90%RH
Incorrect Attempt Alarm	5
Anti-pry Alarm	Supported
Door Ajar Alarm	Supported
Coerce Alarm	Supported
One-click Arming Alarm	Supported
LV Alarm	Supported









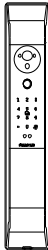

V. Frequently Asked Questions

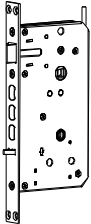
Questions	Possible Causes	Solutions
Information as "System Locked"	5 consecutive incorrect unlock attempts	Wait 90 seconds before retrying with the correct unlock information.
The system emits two beeps.	Incorrect password	Re-enter the correct password.
"Low battery, please renew" as prompted by the system	Low battery	Replace the battery promptly.
Facial recognition fails to unlock	Human detection disabled	Press "05#" to turn on or off the human detection function.
Alarm triggered without any abnormal activity	Installation causing the anti-pry alarm to falsely activate	Tighten the screws; reinstall the lock, adding a shim at the anti-pry switch.
Numeric password forgotten		Unlock the door with fingerprint or mechanical key, then register a new password.
Lock fails to automatically engage	Non-official door strips; large door gap	Use official door strips; custom strips.
Short battery life	Non-original battery; lithium battery applied with fast charging	Use original battery; replace battery with new one.
Unable to connect to network	Poor Wi-Fi signal; or special characters in Wi-Fi name	Move the router closer to the lock; modify the Wi-Fi name (numbers or English).

Attention

- If the aforementioned solutions do not resolve your issue, please contact customer support for professional assistance.
- Avoid using consecutive or identical digits for your password.
- It is recommended to enable the combination unlocking function.
- When human detection is disabled, facial recognition requires waking up the screen to unlock the door. The passive alarm is also turned off. When human detection is enabled, the door can be unlocked even when the screen is in sleep mode. If someone stays near the door for 15 seconds, the lock will emit an alarm sound.

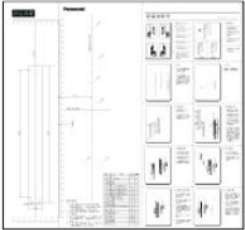
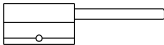
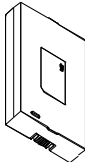
VI. Product List

 <p>Front Panel *1</p>	 <p>Rear Panel *1</p>	 <p>Lock Body *1</p>
 <p>Screw Pack *1</p>	 <p>Card*4</p>	 <p>Door Frame Bracket*1</p>
 <p>AA Battery*4</p>	 <p>User Manual*1</p>	 <p>Installation Instructions and Templates*1</p>
 <p>Lock Head*1</p>	 <p>Lithium Battery*1</p>	 <p>Key*2</p>

These pictures are for reference purpose only. The actual product shall prevail.

VIII. After-sales Service

- 1) Within the warranty period, if the service personnel at Shun Hing Electric Service Centre Ltd. confirm that the product failure occurred under normal usage conditions, the Company will provide free repairs and replacement of parts. Any defective parts replaced will become the Company's property.
- 2) The warranty does not cover repairs or replacements of consumable parts, accessories, external cables, or casings. Additional charges will apply for such services.
- 3) The warranty will be void if any of the following conditions are found on the appliances listed on the warranty card:
 - The product has been modified, altered or repaired by non-authorized technicians, either visibly or invisibly;
 - The product has been misused, improperly used, or neglected, or damaged by liquid immersion, water splashes, abnormal power supply, natural disasters, accidents, or external factors;
 - The product is not installed at a fixed land location;
 - The installation location adversely affects normal operation;
 - Non-industrial/commercial models are used for industrial/commercial purposes;
 - The user relocates or changes ownership without timely notification to Shun Hing Electric Service Centre Ltd.
- 4) Users are required to present the purchase receipt and warranty card during repairs. For any inquiries, please contact Shun Hing Electric Service Centre Ltd. at our hotline: 2406 5666.

Certificate

The product batch number can be found on the product nameplate or packaging. This product has passed quality inspection.

Quality :
Inspector :





信興電工工程有限公司

辦公室：香港九龍尖沙咀東部麼地道67號半島中心9樓

電話：2861 2767 傳真：2865 6706

網址：<http://www.shew.com.hk>

電郵：shew@shunhinggroup.com

SHUN HING ELECTRIC WORKS AND ENGINEERING CO., L TD.

Office : 9/F., Peninsula Centre, 67 Mody Road, Tsimshatsui East, Kowloon, H.K.

Tel : 2861 2767 Fax : 2865 6706

Website : <http://www.shew.com.hk>

E-mail : shew@shunhinggroup.com

保養及維修 Maintenance and Repair Service:

信興電器服務中心有限公司

地址：香港新界葵涌勝耀街2號信興中心11樓

電話：2406 5666 傳真：2408 0316

網址：<http://www.shesc.com>

SHUN HING ELECTRIC SERVICE CENTRE LTD.

Address : 11/F, Shun Hing Centre, 2 Shing Yiu Street, Kwai Chung, N.T., H .K.

Tel : 2406 5666 Fax : 2408 0316

Website : <http://www.shesc.com>

客戶服務中心Customer Service Centre

- 地址
- 1) 香港新界葵涌勝耀街2號信興中心1樓
 - 2) 九龍尖沙咀東部麼地道67號半島中心B座9樓
 - 3) 香港天后琉璃街7號柏景中心22樓
 - 4) 澳門慕拉士大馬路193-199號南嶺工業大廈5樓I座

- Address
- 1) 1/F, Shun Hing Centre, 2 Shing Yiu Street, Kwai Chung, N.T.
 - 2) 9/F., Block B, Peninsula Centre, 67 Mody Road, Tsim Sha Tsui, Kowloon.
 - 3) 22/F, Parkview Centre, 7 Lau Li Street, Tin Hau, Hong Kong.
 - 4) Avenida de Venceslau de Morais, No. 193-199, 5 andar-I, Edf. Industrial Nam Leng, Macau

有關最新之香港及澳門客戶服務中心資料，請參閱信興服務中心

網址：<http://www.shesc.com>

For the latest information of Hong Kong and Macau service center, please visit

Website : <http://www.shesc.com>